



USER MANUAL



GT15000E

Portable Generator

10500 Running Watts | 11500 Peak Watts

WARNING

Operating, servicing and maintaining this equipment can expose you to chemicals including engine exhaust, carbon monoxide, phthalates, and lead, which are known to the State of California to cause cancer and birth defects or other reproductive harm. To minimize exposure, avoid breathing exhaust, do not idle the engine except as necessary, service your equipment in a well-ventilated area and wear gloves or wash your hands frequently when servicing your equipment.

DISCLAIMERS:

All information, illustrations and specifications in this manual are based on the latest information available at the time of publishing. The illustrations used in this manual are intended as representative reference views only. Moreover, because of our continuous product improvement policy, we may modify information, illustrations and/or specifications to explain and/or exemplify a product, service or maintenance improvement. We reserve the right to make any change at any time without notice. Some images may vary depending upon which model is shown.

DANGER



This manual contains important instructions for operating this generator. For your safety and the safety of others, be sure to read this manual thoroughly before operating the generator. Failure to properly follow all instructions and precautions can cause you and others to be seriously hurt or killed.

GT POWER TECHNICAL SPECIFICATIONS

| Model Number | Running Watts | Peak Watts | Fuel Tank Size (L/G) | Rated Speed (RPM) | Ignition Type | Spark plug | Engine Disp (cc) | Stroke X Bore | Oil Capacity (L) | Oil Type | THD |
|--------------|---------------|------------|----------------------|-------------------|---------------|-------------|------------------|---------------|------------------|----------|-----|
| GT15000E | 12000 | 15000 | 40 L 10.5 G | 3600 | TCI | Bosch F7RTC | 713cc | 71X80 | 1.6 L | 10W30 | <5% |

| Engine Type | Starting System | Noise Level | Run Time | Power Outlets | Dimensions | Weight |
|--------------|-----------------|-------------|-----------------|---------------|-----------------|--------|
| 4 Stroke OHV | Electric/Recoil | 76dB | 9hrs @ 50% load | 3 | 900 x 620 x 950 | 153kg |

NOTICE

This generator is not equipped with altitude carburetor modification. Even with a carburetor modification, engine horsepower will decrease about 3.5% for each 300 meter (1,000 foot) increase in altitude. The effect of altitude on horsepower will be greater if no carburetor modification is made. A decrease in engine horsepower will decrease the power output of the generator. Contact our service team to order altitude kits.

HAVE QUESTIONS?

Email us at customerservice@euroquip.co.nz
or call 0800 387 678

FOR YOUR RECORDS:

| | |
|------------------------------|--|
| Date of Purchase: | |
| Generator Model Number: | |
| Purchased from Store/Dealer: | |
| Generator Serial Number: | |

IMPORTANT: KEEP YOUR PURCHASE RECEIPT TO ENSURE TROUBLE-FREE WARRANTY COVERAGE.

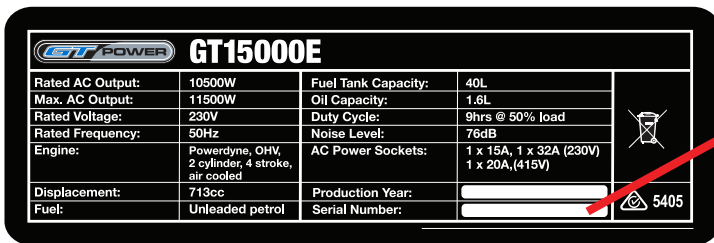

SERIAL NUMBER

Model info decal located on back side
above muffler

Serial Number which is located on
right side of model info decal

TABLE OF CONTENTS

| | | | |
|---|----|---|----|
| GT POWER TECHNICAL SPECIFICATIONS | 2 | MAINTENANCE | 20 |
| PRODUCT REGISTRATION | 3 | Maintenance Schedule | 20 |
| For Your Records: | 3 | Engine Oil Maintenance | 21 |
| Product Registration | 3 | Engine Oil Specification | 21 |
| Product Registration Form | 3 | Checking Engine Oil | 21 |
| SAFETY | 5 | Adding Engine Oil | 21 |
| Safety Definitions | 5 | Changing Engine Oil | 22 |
| Safety Symbol Definitions | 5 | Air Filter Maintenance | 22 |
| General Safety Rules | 6 | Cleaning the Air Filter | 22 |
| UNPACKING | 7 | Spark Plug Maintenance | 23 |
| What Comes in the Box | 7 | VFT Maintenance Reminders | 23 |
| ASSEMBLY | 8 | Checking and Adjusting Valve Lash | 24 |
| Installing Wheels and Feet | 8 | Battery Service | 24 |
| Installing Lift Bracket | 8 | Battery Replacement | 24 |
| Installing the Battery | 9 | Cleaning the Generator | 25 |
| FEATURES | 10 | Cleaning Spark Arrestor | 25 |
| Generator Features | 10 | Storage | 25 |
| Control Panel Features | 11 | TROUBLE SHOOTING | 26 |
| OPERATION | 12 | EXPLODED AND ENGINE VIEWS | 28 |
| Before Starting the Generator | 12 | GT15000E Exploded View | 28 |
| High Altitude Operation | 13 | GT15000E Exploded View Part Numbers | 29 |
| How to Ground Generator | 13 | GT15000E Engine View | 30 |
| Connecting the Generator to Building Electrical | 13 | GT15000E Engine View Part Numbers | 31 |
| System | | GT15000E Schematic | 33 |
| How to Float the Neutral | 13 | WARRANTY | 34 |
| Power Cords | 14 | | |
| How to use Lifting Bracket | 14 | | |
| Engine Fluids and Fuel | 15 | | |
| Adding Gasoline to the Fuel Tank | 15 | | |
| Power Output and Demand | 16 | | |
| Starting the Generator | 18 | | |
| Electric Start | 18 | | |
| Remote Start | 18 | | |
| Stopping the Generator | 19 | | |
| Normal Operation | 19 | | |
| During an Emergency | 19 | | |

SAFETY

SAFETY DEFINITIONS

The words DANGER, WARNING, CAUTION and NOTICE are used throughout this manual to highlight important information. Be certain that the meanings of these alerts are known to all who work on or near the equipment.



This safety alert symbol appears with most safety statements. It means attention, become alert, your safety is involved! Please read and abide by the message that follows the safety alerts symbol.

DANGER

Indicates a hazardous situation which, if not avoided, *will* result in death or serious injury.

WARNING

Indicates a hazardous situation which, if not avoided, *could* result in death or serious injury.

CAUTION

Indicates a hazardous situation which, if not avoided, *could* result in minor or moderate injury.

NOTICE

Indicates a situation which can cause damage to the generator, personal property and/or the environment, or cause the equipment to operate improperly.

NOTE: Indicates a procedure, practice or condition that should be followed in order for the generator to function in the manner intended.

SAFETY SYMBOL DEFINITIONS

| Symbol | Description |
|---|--|
|  | Safety Alert Symbol |
|  | Asphyxiation Hazard |
|  | Burn Hazard |
|  | Burst/Pressure Hazard |
|  | Don't leave tools in the area |
|  | Electrical Shock Hazard |
|  | Explosion Hazard |
|  | Fire Hazard |
|  | Lifting Hazard |
|  | Pinch-Point Hazard |
|  | Read Manufacturer's Instructions |
|  | Read Safety Messages Before Proceeding |
|  | Wear Personal Protective Equipment (PPE) |

SAFETY

GENERAL SAFETY RULES

DANGER



Never use the generator in a location that is wet or damp. Never expose the generator to rain, snow, water spray or standing water while in use. Protect the generator from all hazardous weather conditions. Moisture or ice can cause a short circuit or other malfunction in the electrical circuit.



Never operate the generator in an enclosed area. Engine exhaust contains carbon monoxide. Only operate the generator outside and away from windows, doors and vents.

WARNING



Voltage produced by the generator could result in death or serious injury.

- Never operate the generator in rain or a flood plain unless proper precautions are taken to avoid being subject to rain or a flood.
- Never use worn or damaged extension cords.
- Always have a licensed electrician connect the generator to the utility circuit.
- Never touch an operating generator if the generator is wet or if you have wet hands.
- Never operate the generator in highly conductive areas such as around metal decking or steel works.
- Always use grounded extension cords. Always use three-wire or double-insulated power tools.
- Never touch live terminals or bare wires while the generator is operating.
- Be sure the generator is properly grounded before operating.

WARNING



Gasoline and gasoline vapors are extremely flammable and explosive under certain conditions.

- Always refuel the generator outdoors, in a well-ventilated area.
- Never remove the fuel cap with the engine running.
- Never refuel the generator while the engine is running. Always turn engine off and allow the generator to cool before refueling.
- Only fill fuel tank with gasoline.
- Keep sparks, open flames or other form of ignition (such as match, cigarette, static electric source) away when refueling.
- Never overfill the fuel tank. Leave room for fuel to expand. Overfilling the fuel tank can result in a sudden overflow of gasoline and result in spilled gasoline coming in contact with HOT surfaces. Spilled fuel can ignite. If fuel is spilled on the generator, wipe up any spills immediately. Dispose of rag properly. Allow area of spilled fuel to dry before operating the generator.
- Wear eye protection while refueling.
- Never use gasoline as a cleaning agent.
- Store any containers containing gasoline in a well-ventilated area, away from any combustibles or source of ignition.
- Check for fuel leaks after refueling. Never operate the engine if a fuel leak is discovered.

WARNING



Never operate the generator if powered items overheat, electrical output drops, there is sparking, flames or smoke coming from the generator, or if the receptacles are damaged.



Never use the generator to power medical support equipment.



Always remove any tools or other service equipment used during maintenance from the generator before operating.

NOTICE

Never modify the generator.

Never operate the generator if it vibrates at high levels, if engine speed changes greatly or if the engine misfires often.

Always disconnect tools or appliances from the generator before starting.

UNPACKING

CAUTION



Always have assistance when lifting the generator. The generator is heavy; lifting it could cause bodily harm.



Avoid cutting on or near staples to prevent personal injury.

WHAT COMES IN THE BOX (GT15000E)

Owners Manual

Wireless Remote Starter (1)

1.6 Liter Bottle of SAE 10W30 Oil (1)

Spark Plug Socket Wrench (1)

Battery Charger

Wheel Kit Accessories Box

Lift bracket with bolts

Pins for handles

Oil funnel (1)

ASSEMBLY

INSTALLING WHEELS AND FEET



BEFORE ASSEMBLING THE GENERATOR, REVIEW THE SAFETY SECTION STARTING ON PAGE 5.

CAUTION



Never lift the generator without assistance. The generator is heavy and lifting without assistance could result in personal injury.



Never use the handles as a lifting point to support the entire weight of the generator. Only use the handles to move the generator by lifting the handles and using the wheels to move the generator.



Use caution when collapsing the handles. Hands and fingers could get caught and pinched.

NOTICE

Assembling the generator will require lifting the unit on one side. Make sure all engine oil and fuel are drained from the unit prior to assembling. Once assembled, the wheel kit is not intended for on-road use. The wheel kit is designed for use on this generator only.

INSTALLING WHEELS TO FRAME

1. Insert axle bolt through washer and wheel and slide hairpin cotter into top of the axle bolt to prevent it from sliding off the wheel.

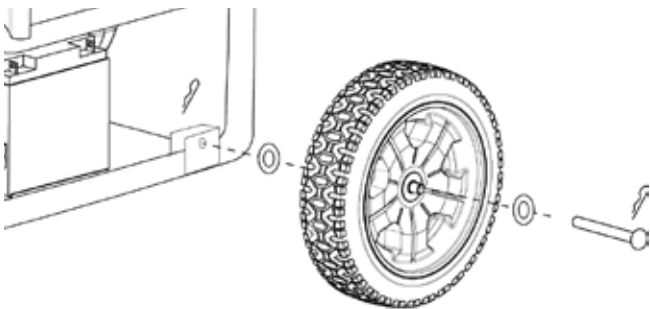

Figure 1 - Install Wheels

2. Install the axle bolt and wheel through another washer and then through the axle bracket on the frame.

3. Install the hairpin cotter through the end of the axle bolt to lock it in place.
4. Repeat previous steps on other wheel.

INSTALLING LIFT BRACKET

1. Align the lifting bar with the mounting brackets on the top of the fuel tank and secure with the 4 M8 flange bolts provided.

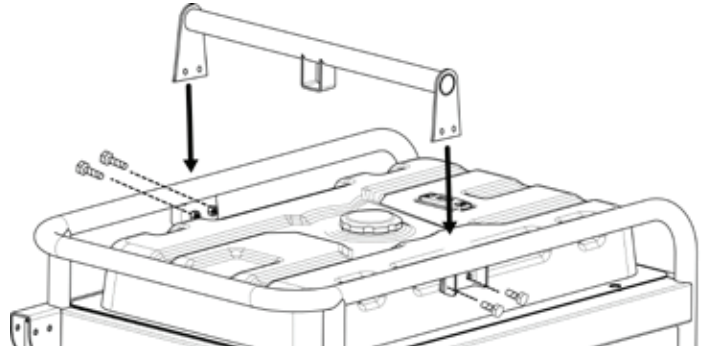

Figure 2 - Install Lift Bracket

ASSEMBLY

INSTALLING THE BATTERY

⚠ WARNING



To avoid electric shock:

- ALWAYS connect the positive (+) battery cable (red boot) first when connecting battery cables.
- ALWAYS disconnect the negative (-) battery cable (black boot) first when disconnecting battery cables.
- NEVER connect the negative (-) battery cable (black boot) to the positive (+) post on the battery.
- NEVER connect the positive (+) battery cable (red boot) to the negative (-) post on the battery.
- NEVER touch both battery posts simultaneously.
- NEVER place a metal tool across both battery posts.
- ALWAYS use insulated or nonconducting tools when installing the battery.

1. Remove the two bolts holding on the battery plate. Tilt the battery forward and remove.

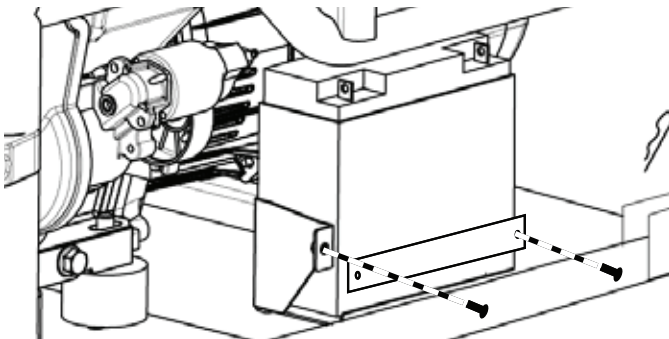

Figure 3 - Remove Battery

2. Connect the positive (+) battery cable (red boot) to the positive (+) battery post. Make sure boot is over battery post.
3. Locate negative (-) cable (black boot) and connect to the negative (-) battery post. Make sure the boot is over the battery post.

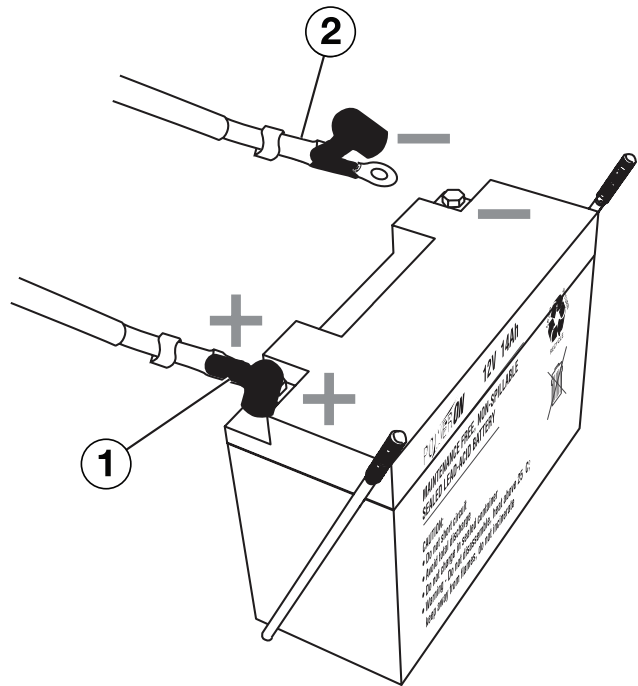

Figure 4 - Connect battery

- 1 - Positive (+) Battery Cable (Red)
- 2 - Negative (-) Battery Cable (Black)

NOTE: The electric start generator is equipped with a battery charging feature. Once the engine is running, a small charge is supplied to the battery via the battery cables and will slowly recharge the battery.

FEATURES



- ① **Push Button Electric Start:** Starts and stops the engine.
- ② **Fuel Cap:** Close until clicking sound is heard.
- ③ **Control Panel:** Contains the circuit breakers and outlets.
- ④ **Battery:** Included for electric start models.
- ⑤ **Oil Fill Plug:** Must be removed to add oil.
- ⑥ **Oil Drain Plug:** Must be removed to drain engine oil
- ⑦ **Oil Dipstick:** Used to check correct oil levels.
- ⑧ **Fuel Shut off Valve:** Controls the flow of fuel to the engine.
- ⑨ **Lifting Bracket:** Bracket to lift generator at using a crane.
- ⑩ **Fuel Gauge:** Indicates fuel level.
- ⑪ **Spark Plug Boot (Wire):** Must be removed when servicing the engine or the spark plug.

- ⑫ **Remote Start Pairing Button:** Initiates the remote key fob pairing function.
- ⑬ **Alternator Cover:** Gain access to alternator wiring.
- ⑭ **CARB Canister:** Required for models sold into and used in California.
- ⑮ **Muffler and Spark Arrester:** Avoid contact until engine is cooled down. Spark arrestor prevents sparks from exiting the muffler. It must be removed for servicing.
- ⑯ **Never Flat Wheels:** For easy portability

FEATURES

CONTROL PANEL FEATURES

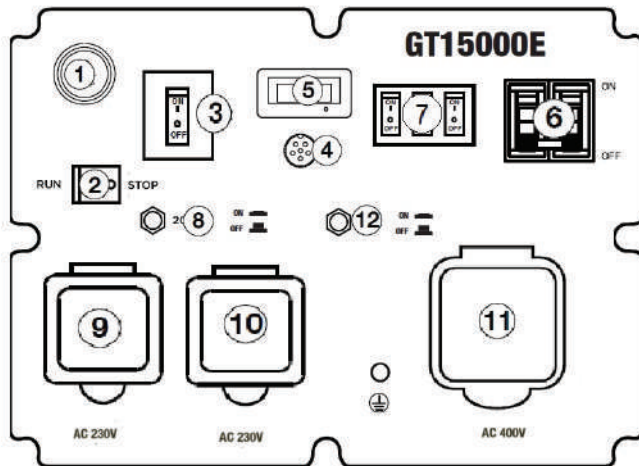

- ① **Push Button Electric Start:** Starts and stops the engine.
- ② **Engine Control Switch/Battery Disconnect:** Switch to “Stop” to stop the engine. When in “Stop” position it prevents the unit from drawing power from the battery. Switch to “Run” before starting engine.
- ③ **Single Phase Circuit Breaker**
- ④ **Smart Switch Outlet**
- ⑤ **VFT Data Center:** Press and release the mode button to toggle between Voltage, Frequency, Total Hour Meter and Run/Maintenance Timer

U 250 Voltage
F - 60 Frequency in hertz
00:07 Lifetime run hours
00:00 Run/Maintenance

The Run/Maintenance Timer displays the time in hours and minutes each time the generator is ran. The run timer resets to 00:00 when the generator is shut off. Built into this run timer is maintenance reminder.

- ⑥ **Main Circuit Breaker:** The main circuit breaker controls total output of all outlets to protect the generator.
- ⑦ **Three Phase Circuit Breaker**
- ⑧ **15-Amp Circuit Breakers:** Each circuit breaker limits the current that can be delivered through the 230-Volt duplex outlets to 20amps.
- ⑨ **Single Phase, 15-Amp Outlet:** Outlet can supply 230V up to 15 amps.
- ⑩ **Single Phase, 32-Amp Outlet:** Outlet can supply either 230V up to 32 amps.
- ⑪ **Three Phase, 20-Amp Outlet:** Outlet can supply either 240V or 440V up to 20 amps.
- ⑫ **32-Amp Circuit Breaker:** Circuit breaker limits the current that can be delivered through the 240-Volt duplex outlets to 30amps.

OPERATION

BEFORE STARTING THE GENERATOR



BEFORE STARTING THE GENERATOR, REVIEW SAFETY SECTION STARTING ON PAGE 5.

Location Selection – Before starting the generator, avoid exhaust and location hazards by verifying:

- You have selected a location to operate the generator that is outdoors and well ventilated.
- You have selected a location with a level and solid surface on which to place the generator.
- You have selected a location that is at least 15 feet (4.5 m) away from any building, other equipment or combustible material.
- If the generator is located close to a building, make sure it is not located near any windows, doors and/or vents.

⚠ DANGER

Using a generator indoors
CAN KILL YOU IN MINUTES.
Generator exhaust contains carbon monoxide.
This is a poison you cannot see or smell.



NEVER use inside a home or garage, **EVEN IF** doors and windows are open.



Only use **OUTSIDE** and far away from windows, doors, and vents.

Avoid other generator hazards.
READ MANUAL BEFORE USE.

⚠ WARNING



Always operate the generator on a level surface. Placing the generator on non level surfaces can cause the generator to tip over, causing fuel and oil to spill. Spilled fuel can ignite if it comes in contact with an ignition source such as a very hot surface.

NOTICE

Only operate the generator on a solid, level surface. Operating the generator on a surface with loose material such as sand or grass clippings can cause debris to be ingested by the generator that could:

- Block cooling vents
- Block air intake system

Weather – Never operate your generator outdoors during rain, snow or any combination of weather conditions that could lead to moisture collecting on, in or around the generator.

Dry Surface – Always operate the generator on a dry surface free of any moisture.

No Connected Loads – Make sure the generator has no connected loads before starting it. To ensure there are no connected loads, unplug any electrical extension cords that are plugged into the control panel receptacles.

NOTICE

Starting the generator with loads already applied to it could result in damage to any appliance being powered off the generator during the brief start-up period.

Grounding the Generator – The National Electric Code (NEC), as well as many local electrical codes, may require the generator to be connected to earth ground before operating. The most common application that requires a ground rod is when you are using the generator as a separately derived system to provide back up power to your house. Typically this is when a transfer switch has a switched neutral.

As the generator application has many variables that cannot be determined by the manufacturer of the generator, a licensed electrician will need to determine if a grounding rod is needed.

If a licensed electrician has determine the application requires a ground rod, make sure it is connected to earth ground by connecting the ground terminal on the control panel to earth ground using copper wire (minimum 10 AWG). Consult a qualified electrician for local grounding requirements.

Neutral Bonded: There is a permanent conduct or between the generator (stator winding) and the frame.

⚠ WARNING



Be sure the generator is properly connected to earth ground before operating. The generator must be grounded to prevent electrical shock due to faulty appliances.

OPERATION

HIGH ALTITUDE OPERATION

Engine power is reduced the higher you operate above sea level. Output will be reduced approximately 3.5% for every 1000ft of increased altitude from sea level. This is a natural occurrence and cannot be adjusted by engine. Increased exhaust emissions can also result due to increased fuel mixture. Other issues include hard starting, increased fuel consumption and spark plug fouling.

HOW TO GROUND THE GENERATOR

NOTICE

Grounding codes can vary by location. Please contact a local electrician to check the grounding regulations for your area.

1. Attach grounding wire to the ground on the control panel and secure. A generally acceptable grounding wire is a No. 12 AWG (American Wire Gauge) stranded copper wire.
2. Connect the other end to a copper or brass grounding rod that's driven into the earth.

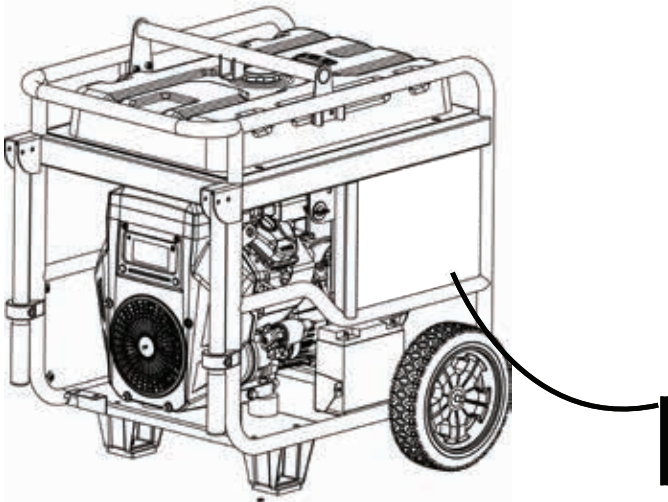

WARNING



Failure to properly ground the generator can result in electrocution.

CONNECTING THE GENERATOR TO A BUILDING ELECTRICAL SYSTEM

It is recommended to use a manual transfer switch when connecting directly to a buildings electrical system. Connecting a portable generator to a buildings electrical system must be made in strict compliance with all national and local electrical codes and laws, and be completed by a qualified electrician.

HOW TO FLOAT THE NEUTRAL

The GT Power generator is wired with the neutral bonded to ground. If you are connecting your generator to a panel board transfer switch, a licensed electrician will need to consider removing the bonded neutral to ensure proper operation of household GFCI circuits.

Begin by removing the alternator cover. Once the cover is off, remove the (white) bonded ground jumper wire by removing the two nuts that hold it in place. Once the wire is removed, make sure to reattach the nuts without removing any other wires that are underneath the jumper wire. See picture below:

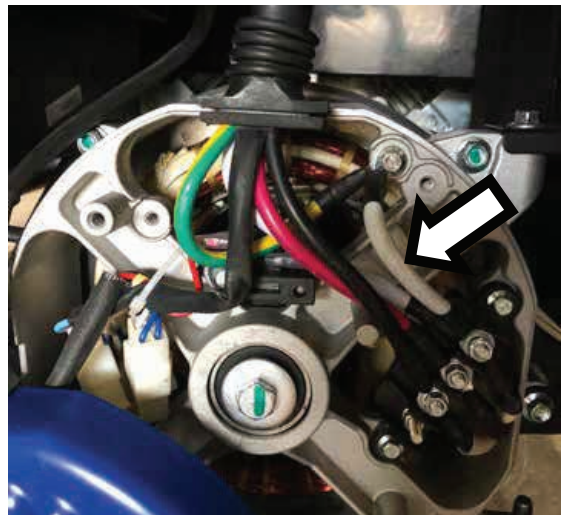

NOTICE

Make sure to keep the white ground jumper wire in case you need to bond the neutral.

If the bonded neutral is removed the generator must be relabeled as floating neutral on the control panel. If your generator is equipped with GFCI receptacles, removing the bonded neutral may not allow proper operation of the GFCI receptacles.

OPERATION

| Amps | Extension Cord Wire Gauge Size | | | | | | | | |
|------|--------------------------------|----|----|----|----|----|----|-----|-----|
| | Length of Extension Cord (ft) | | | | | | | | |
| | 10 | 20 | 30 | 40 | 50 | 60 | 80 | 100 | 120 |
| 5 | 20 | 18 | 16 | 14 | 12 | 12 | 10 | 10 | 8 |
| 10 | 18 | 16 | 14 | 12 | 12 | 10 | 10 | 8 | 8 |
| 15 | 16 | 14 | 12 | 12 | 10 | 10 | 8 | 8 | 6 |
| 20 | 14 | 12 | 12 | 10 | 10 | 8 | 8 | 6 | 6 |
| 25 | 12 | 12 | 10 | 10 | 8 | 8 | 6 | 6 | 6 |
| 30 | 12 | 10 | 10 | 8 | 8 | 6 | 6 | 6 | 6 |
| 35 | 10 | 10 | 8 | 8 | 6 | 6 | 6 | 6 | 6 |
| 40 | 10 | 8 | 8 | 6 | 6 | 6 | - | - | - |
| 45 | 8 | 8 | 6 | 6 | 6 | - | - | - | - |
| 50 | 8 | 6 | 6 | 6 | - | - | - | - | - |

POWER CORDS

Using Extension Cords

GT Power Portable Power assumes no responsibility for the content within this table. The use of this table is the responsibility of the user only. This table is intended for reference only. The results produced by using this table are not guaranteed to be correct or applicable in all situations as the type and construction of cords are highly variable. Always check with local regulations and a licensed electrician prior to installing or connecting an electrical appliance.

LIFTING BRACKET

1. Before lifting the generator, inspect the bracket and make sure it is securely fastened to the generator. Do not lift the generator unless the lifting bracket is securely fastened.
2. Hook a chain or strap through the eye on the lifting bracket and make sure it is securely fastened.
3. Connect a suitable lifting device to the chain or strap. Inspect chain and hook for any damaged links or any defects that could cause failure. It is recommended to use hooks with safety latches installed.
4. Lift the generator slightly to ensure it is lifting straight and level. Adjust the bracket if required to allow it to lift correctly.

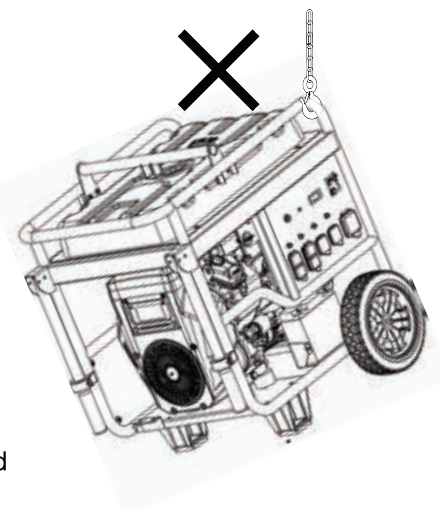
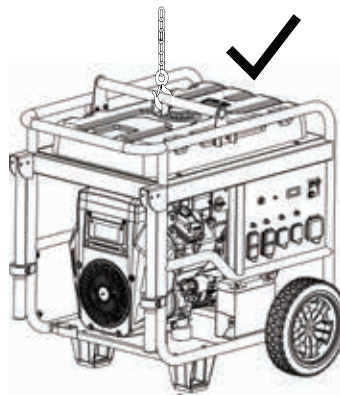

Do not lift anywhere else than the eye on the lifting bracket. Improper lifting could damage unit.

OPERATION

ADDING / CHECKING ENGINE FLUIDS AND FUEL



BEFORE ADDING/CHECKING ENGINE FLUIDS AND FUEL, REVIEW SAFETY SECTION STARTING ON PAGE 5.

DANGER



Filling the fuel tank with gasoline while the generator is running can cause gasoline to leak and come in contact with hot surfaces that can ignite the gasoline.

Before starting the generator, always check the level of:

- Engine oil
- Gasoline in the fuel tank

Once the generator is started and the engine gets warm, it is not safe to add gasoline to the fuel tank or engine oil to the engine while the engine is running or the engine and muffler are hot.

CHECKING AND / OR ADDING ENGINE OIL

WARNING



Internal pressure can build in the engine crankcase while the engine is running. Removing the oil fill plug/ dipstick while the engine is hot can cause extremely hot oil to spray out of the crankcase and can severely burn skin. Allow engine oil to cool for several minutes before removing the oil fill plug/dipstick.

The unit as shipped does not contain oil in the engine. You must add engine oil before starting the generator for the first time. See *Checking Engine Oil* and *Adding Engine Oil* for instructions on checking engine oil level and the procedure for adding engine oil.

NOTICE

The engine does not contain engine oil as shipped. Attempting to start the engine can damage engine components. The owner of the generator is responsible to ensure the proper oil level is maintained during the operation of the generator. Failure to maintain the proper oil level can result in engine damage.

ADDING GASOLINE TO THE FUEL TANK

WARNING



Never refuel the generator while the engine is running.



Always turn the engine off and allow the generator to cool before refueling.

Required Gasoline – Only use gasoline that meets the following requirements:

- Unleaded gasoline only
- Gasoline with maximum 10% ethanol added
- Gasoline with an 87 octane rating or higher

Filling the Fuel Tank – Follow the steps below to fill the fuel tank:

1. Shut off the generator.
2. Allow the generator to cool down so all surface areas of the muffler and engine are cool to the touch.
3. Move the generator to a flat surface.
4. Clean area around the fuel cap.
5. Remove the fuel cap by rotating counterclockwise.
6. Slowly add gasoline into the fuel tank. Be very careful not to overfill the tank. The gasoline level should NOT be higher than the filler neck (see Figure 5).
7. Install the fuel cap by rotating clockwise until you hear a click, indicating the cap is completely installed.

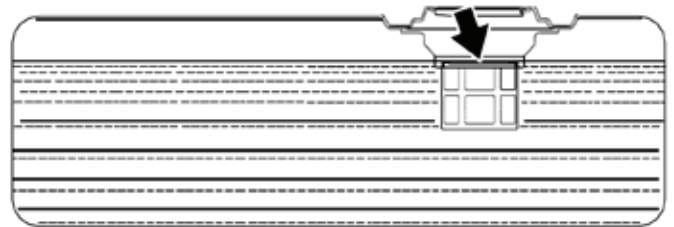

Figure 5 - Maximum Gasoline Fill Level

CAUTION



Avoid prolonged skin contact with gasoline. Avoid prolonged breathing of gasoline vapors.

OPERATION

POWER OUTPUT AND DEMAND

240-Volt AC devices have two different electric power demands that must be taken into consideration, namely the running power and the starting/peak power. Both are measured in Watts (typically abbreviated as “W”).

The steady state continuous load is the running power demand and this is often marked on the device near its model number or serial number. Sometimes the device might only be marked with its voltage (i.e. 120 V) and current draw (e.g. 6 Amp or 6 A), in which case the running power demand in Watts can be obtained by multiplying the voltage times the current, e.g. $120\text{ V} \times 6\text{ A} = 720\text{ W}$.

Simple resistive 240-Volt AC devices such as incandescent bulbs, toasters, heaters, etc. have no extra power demand when starting, and so their starting power demands are the same as their running power demands.

More complex 240-Volt AC devices containing inductive or capacitive elements such as electric motors have a momentary extra power demand when starting, which can be up to seven times the running power demand or more. Manufacturers of such devices rarely publish this starting power demand and so it's often necessary to estimate it. A rule of thumb for devices fitted with an electric motor is to apply a starting power multiplier of 1.2 for small hand-held or portable devices and a value of 3.5 for larger stationary devices. For example, a 900 W angle grinder can be assumed to have a starting power demand of at least $1.2 \times 900\text{ W}$, which equals 1,080 W. Similarly, a 1,650 W air compressor can be assumed to have a starting power demand of at least $3.5 \times 1,650\text{ W}$, which equals 5,775 W.

To prevent overloading of the generator's 240-Volt AC system:

1. Add up the running power demand of all the 240-Volt AC devices that will be connected to the generator at one time. This total must not be greater than the generator's specified running power output.
2. Add up the running power demand again, but for the largest motor-driven device use the value of its starting power demand instead of its running power demand. This total must not be greater than the generator's specified starting power output.
3. The total running power demand of all the devices that will be connected to any one of the generator's outlets must not exceed the generator's specified running power output.

OPERATION

BEFORE STARTING THE GENERATOR



BEFORE STARTING THE GENERATOR, REVIEW SAFETY SECTION STARTING ON PAGE 5.

Before attempting to start the generator, verify the following:

- The engine is filled with engine oil. See *Checking Engine Oil*.
- The generator is situated in a proper location. See *Location Selection*.
- The generator is on a dry surface. See *Weather and Dry Surface*.
- All loads are disconnected from the generator. See *No Connected Loads*.
- The generator is properly grounded the Generator. See *Grounding the Generator*.

DANGER



Never use the generator in a location that is wet or damp. Never expose the generator to rain, snow, water spray or standing water while in use. Protect the generator from all hazardous weather conditions. Moisture or ice can cause a short circuit or other malfunction in the electrical circuit.



Never operate the generator in an enclosed area. Engine exhaust contains carbon monoxide. Only operate the generator outside and away from windows, doors and vents.

NOTICE

The engine is equipped with a low oil shutdown switch. If the oil level becomes low, the engine may shut down and not start until the oil is filled to the proper level. Poor oil quality may interfere with the operation of the low oil shutdown switch.

The owner of the generator is responsible to ensure the proper oil level is maintained during the operation of the generator. Failure to maintain the proper oil level can result in engine damage.

This generator is equipped with an automatic choke for starting. This system is always on and cannot be turned off. Do not attempt to make adjustments to the automatic choke or any other carburetor adjustments. Tampering with the automatic choke system may void your warranty. See an authorized GT Power service center for more information.

OPERATION

STARTING THE GENERATOR

Be sure to check oil levels before starting. If it is the first time starting make sure to add oil (see *Adding Engine Oil*).

1. Make sure nothing is plugged into power outlets.
2. Verify the battery is properly installed and both battery cables are attached (see *Connecting the Battery*).
3. Make sure the circuit breakers are properly set (see Figure 6 below).

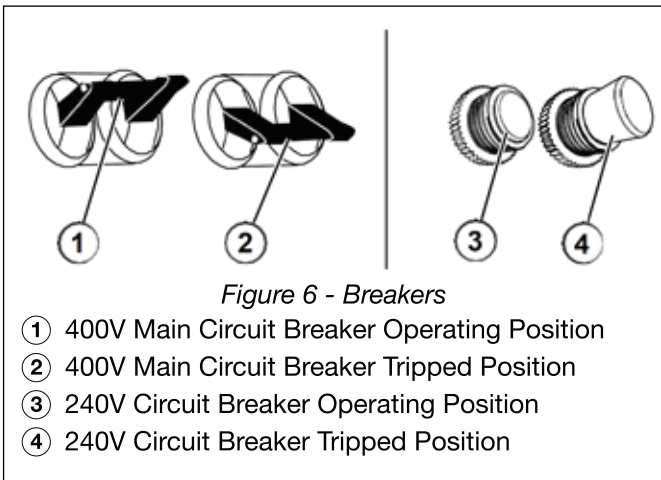

4. Move the fuel shut off valve to the **ON** position (see Figure 7 below).

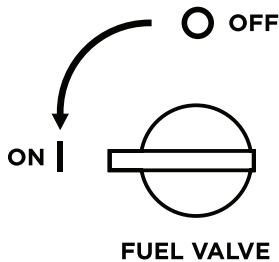

Figure 7 - Fuel Shut Off - ON

5. Push the engine control switch into the **RUN** position (see Figure 8).

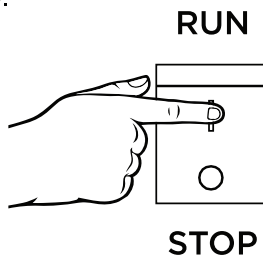

Figure 8 - Engine Control Switch - RUN

6. Push and hold the push button start for 1 second, then release. If using remote start then hold down **START** on the remote key fob until the generator starts, then release (see Figure 9).

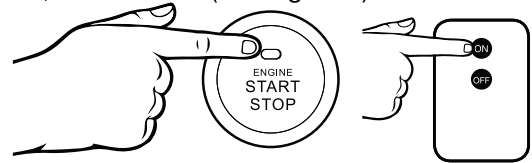

Figure 9 - Push Button Start/Remote Start

- The engine will automatically set the choke and begin the start sequence.
- If the engine has started successfully the light indicator on the engine start button will turn green.
- If the engine fails to start, the generator controls will attempt to start the engine two more times for a total of three attempts.
- If the third attempt fails, the light on the engine start button will turn red.
- If the engine has failed to start after three attempts the push button start can be pushed again to begin the automatic start sequence.
- The engine control switch can be switched at any time during the automatic start sequence to abort the engine start attempt.

NOTE: If the cranking speed drops after each unsuccessful attempt, then the battery may not be adequately charged. You can use the charger provided to charge the battery by plugging it into the battery charging port on the control panel.

7. Plug in electric devices.

OPERATION

STOPPING THE GENERATOR

Normal Operation

During normal operation, use the following steps to stop your generator:

1. Remove any connected loads from the control panel receptacles.
2. Allow the generator to run at “no load” to reduce and stabilize engine and alternator temperatures.
3. Position the engine control switch to **STOP** (see figure 10).

NOTE If you plan to store the generator after use, turn the fuel shutoff valve to the **OFF** position and allow the fuel to be consumed from the carburetor.

4. To stop generator remotely hold the **OFF** button on the wireless control (see figure 11). The generator may run for an additional 5 seconds as it goes through a cool down cycle before shutting off.
5. Turn the fuel shutoff valve to the **OFF** position.

During an Emergency

If there is an emergency and the generator must be stopped quickly, position the engine control switch to the **STOP** position immediately.

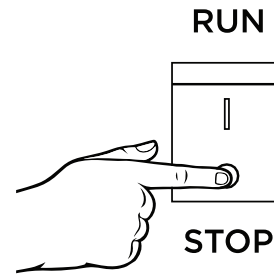

Figure 10 - Engine Control Switch to - STOP

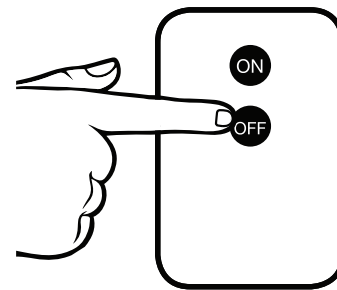

Figure 11 - Remote Stop - Hold Stop Button

MAINTENANCE



BEFORE PERFORMING MAINTENANCE ON THE GENERATOR, REVIEW THE SAFETY SECTION STARTING ON PAGE 5, AS WELL AS THE FOLLOWING SAFETY MESSAGES.

⚠ WARNING



Avoid accidentally starting the generator during maintenance by removing the spark plug boot from the spark plug. For electric start generators, also disconnect the battery cables from the battery (disconnect the black negative (-) cable first) and place the cables away from the battery posts to avoid arcing.



Allow hot components to cool to the touch prior to performing any maintenance procedure.

⚠ WARNING



Internal pressure can build in the engine crankcase while the engine is running. Removing the oil fill plug/dipstick while the engine is hot can cause extremely hot oil to spray out of the crankcase and can severely burn skin. Allow engine oil to cool for several minutes before removing the oil fill plug/dipstick.



Always perform maintenance in a well-ventilated area. Gasoline fuel and fuel vapors are extremely flammable and can ignite under certain conditions.

MAINTENANCE

MAINTENANCE SCHEDULE

⚠ WARNING



Failure to perform periodic maintenance or not following maintenance procedures can cause the generator to malfunction and could result in death or serious injury.

NOTICE

Periodic maintenance intervals vary depending on generator operating conditions. Operating the generator under severe conditions, such as sustained high-load, high-temperature, or unusually wet or dusty environments, will require more frequent periodic maintenance. The intervals listed in the maintenance schedule should be treated only as a general guideline.

⚠ CAUTION



Avoid skin contact with engine oil or gasoline. Prolonged skin contact with engine oil or gasoline can be harmful. Frequent and prolonged contact with engine oil may cause skin cancer. Take protective measures and wear protective clothing and equipment. Wash all exposed skin with soap and water.

Following the maintenance schedule is important to keep the generator in good operating condition. The following is a summary of maintenance items by periodic maintenance intervals.

TABLE 1: MAINTENANCE SCHEDULE - OWNER PERFORMED

| Maintenance Item | Before Every Use | After First 20 Hours or First Month of Use | After 50 Hours of Use or Every 6 Months | After 100 Hour of Use or Every 6 Months | After 300 Hours of Use or Every Year |
|------------------|------------------|--|---|---|--------------------------------------|
| Engine Oil | Check Level | Change | Change | - | - |
| Cooling Features | Check/Clean | - | - | - | - |
| Air Filter | Check | - | Clean* | - | Replace |
| Spark Arrestor | - | - | - | Check/Clean | - |
| Spark Plug | - | - | - | Check/Clean | Replace |

*Service more frequently if operating in dry and dusty conditions

TABLE 2: MAINTENANCE SCHEDULE - AUTHORIZED GT POWER SERVICE DEALER PERFORMED

| Maintenance Item | Before Every Use | After First 20 Hours or First Month of Use | After 50 Hours of Use or Every 6 Months | After 100 Hour of Use or Every 6 Months | After 300 Hours of Use or Every Year |
|------------------|------------------|--|---|---|--------------------------------------|
| Valve Clearance | - | - | - | - | Check/Adjust |
| Fuel Filter | - | - | - | Check/Clean | - |
| Idle Speed | - | - | - | - | Check/Adjust |

MAINTENANCE

ENGINE OIL MAINTENANCE

Engine Oil Specification

1. Only use the engine oil specified in Figure 12.
2. Only use 4-stroke/cycle engine oil. **NEVER USE 2-STROKE/CYCLE OIL.** Synthetic oil is an acceptable substitute for conventional oil.

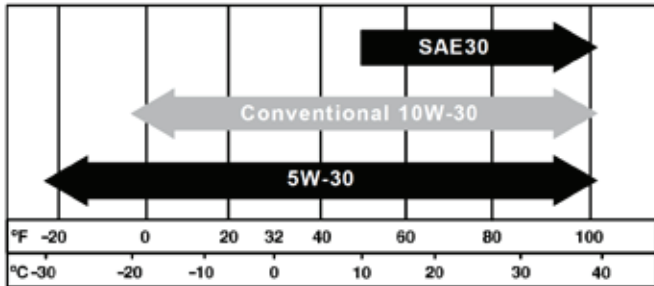

Figure 12 - Recommended Oil

CHECKING ENGINE OIL

NOTICE

Always maintain proper engine oil level. Failure to maintain proper engine oil level could result in severe damage to the engine and/or shorten the life of the engine. Always use the specified engine oil. Failure to use the specified engine oil can cause accelerated wear and/or shorten the life of the engine.

Engine oil level should be checked before every use.

1. Always operate or maintain the generator on a flat surface.
2. Stop engine if running.
3. Let engine sit and cool for several minutes (allow crankcase pressure to equalize).
4. With a damp rag, clean around the oil fill dipstick.
5. Remove oil fill dipstick (see Figure 13 below).

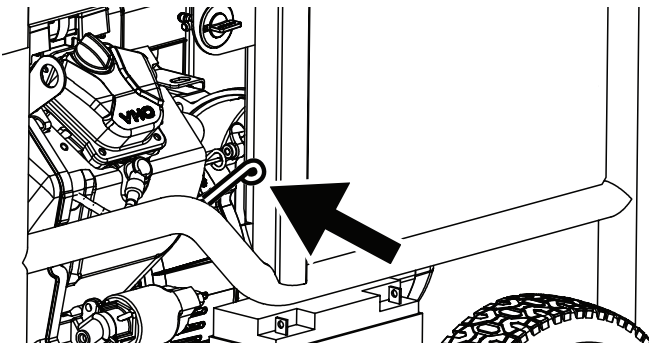

Figure 13 - Oil Dipstick

6. Check oil level: When checking the engine oil, remove the oil dipstick and wipe it clean. Push the oil dipstick all the way back in and then remove and check the oil level on the oil dipstick.

- **Acceptable Oil Level** – Oil is visible on the flat part of the end of the stick up to the first notch. (see Figure 14).
- **Low Oil** – Oil is below the first notch on the oil fill dipstick.

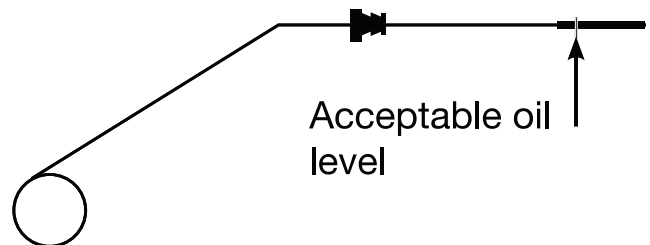

Figure 14 - Checking Oil Level

ADDING ENGINE OIL

1. Always operate or maintain the generator on a flat surface.
2. Stop engine if running.
3. Let engine sit and cool for several minutes (allow crankcase pressure to equalize).
4. Thoroughly clean around the oil fill plug.
5. Remove oil fill plug and wipe clean. (See Figure 15)

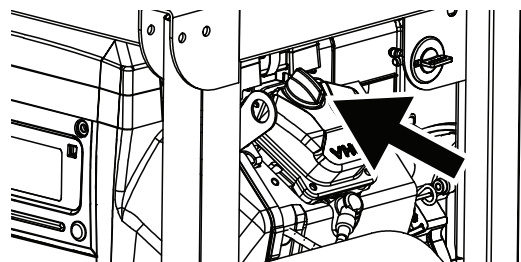

Figure 15 - Oil Fill Plug

6. Select the proper engine oil as specified in Figure 12.
7. Using the supplied funnel, slowly add engine oil to the engine. Stop frequently to check the level to avoid overfilling.
8. Continue to add oil until the oil is at the correct level. See Figure 14.

MAINTENANCE

CHANGING ENGINE OIL

1. Stop the engine.
2. Let engine sit and cool for several minutes (allow crankcase pressure to equalize).
3. Place oil pan (or suitable container) under the oil drain plug (see Figure 16).
4. With a damp rag, thoroughly clean around the oil drain plug.
5. Remove the oil drain plug (see Figure 16). Once removed, place the oil drain plug on a clean surface.

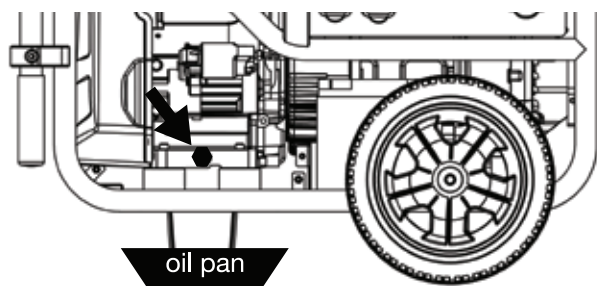

Figure 16 - Oil Drain Plug

6. Allow oil to completely drain.
7. Replace oil drain plug.
8. Fill crankcase with oil following the steps outlined in *Adding Engine Oil*.

NOTICE

Never dispose of used engine oil by dumping the oil into a sewer, on the ground, or into ground water or waterways. Always be environmentally responsible. Follow the guidelines of the EPA or other governmental agencies for proper disposal of hazardous materials. Consult local authorities or reclamation facility.

AIR FILTER MAINTENANCE

WARNING



Never use gasoline or other flammable solvents to clean the air filter. Use only household detergent soap to clean the air filter.

Cleaning the Air Filter

The air filter must be cleaned after every 50 hours of use or 3 months (frequency should be increased if generator is operated in a dusty environment).

1. Turn off the generator and let it cool for several minutes if running.
2. Move the generator to a flat, level surface.
3. Locate the air filter cover on top of the engine. Unclip the 4 clips on the sides of the air filter cover (Figure 17).

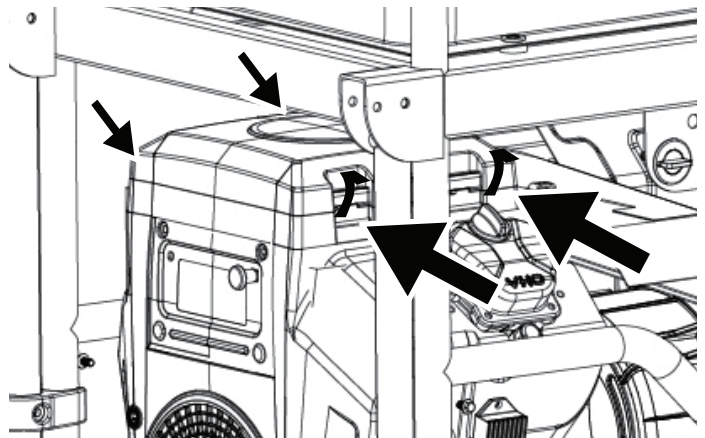

Figure 17 - Unclip air filter cover

4. Clean air filter fins with compressed air to remove debris. Do not submerge in water or add oil.

NOTICE

Do not clean this air filter with liquid or oil. Only compressed air can be used. If the fins or foam element are ripped, replace the filter.

5. Replace the air filter with the correct side up. (See Figure 18). Make sure filter is seated properly.

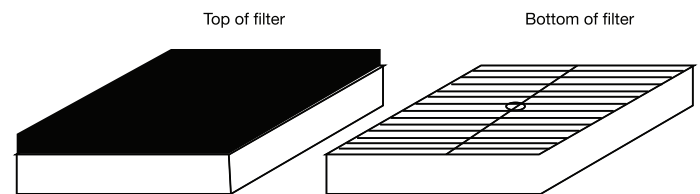

Figure 18 - Air Filter

6. Fasten 4 clips to secure air filter top cover in place.

MAINTENANCE

SPARK PLUG MAINTENANCE

The spark plug must be checked and cleaned after every 100 hours of use or 6 months and must be replaced after 300 hours of use or every year.

1. Stop the generator and let it cool for several minutes if running.
2. Move the generator to a flat, level surface.
3. Remove the spark plug boot by firmly pulling the plastic spark plug boot directly away from the engine (see Figure 19).

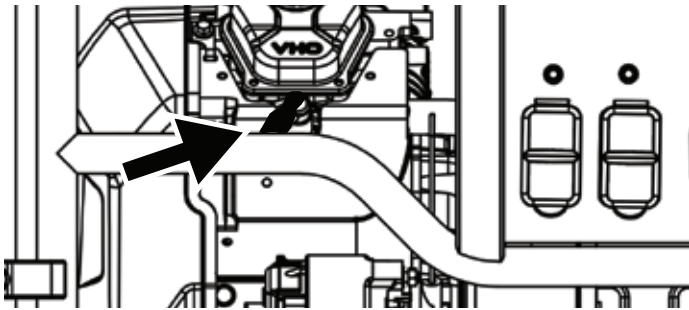

Figure 19 - Remove Spark Plug Boot

NOTICE

Never apply any side load or move the spark plug laterally when removing the spark plug. Applying a side load or moving the spark plug laterally may crack and damage the spark plug boot.

4. Clean area around the spark plug.
5. Using the spark plug socket wrench provided, remove the spark plug from the cylinder head.
6. Place a clean rag over the opening created by the removal of the spark plug to make sure no dirt can get into the combustion chamber.

Inspect the spark plug for:

- Cracked or chipped insulator
- Excessive wear
- Spark plug gap (the acceptable limit of 0.028–0.031 in. [0.70 – 0.80 mm]).

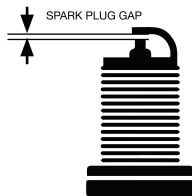

NOTICE

Use only recommended spark plugs when servicing. The manufacturer is not responsible for engine damage when using spark plugs not recommended by the manufacturer.

Recommended Spark Plug Replacement:

NGK: (1034) BP7ES (Replacement)

Bosch: F7TC (OE Spark Plug)

7. Install the spark plug by carefully following the steps outlined below:
 - a. Carefully insert the spark plug back into the cylinder head. Hand-thread the spark plug until it bottoms out.
 - b. Using the spark plug socket wrench provided, turn the spark plug to ensure it is fully seated.
 - c. Replace the spark plug boot, making sure the boot fully engages the spark plug's tip.

MAINTENANCE REMINDERS

DATA CENTER

VOLTS | FREQUENCY | HOURS



The VFT meter on this unit has programmed maintenance reminders. When the VFT meter shows:



P25: This is to remind you to change the oil after the initial 25 hours of run time.



P50: It is time to clean the air filter.



P100: It is time change/clean the fuel filter, clean the air filter, and change the oil.

MAINTENANCE

CHECKING AND ADJUSTING VALVE LASH

CAUTION



Checking and adjusting valve lash must be done when the engine is cold.

1. Remove the rocker arm cover and carefully remove the gasket. If the gasket is torn or damaged, it must be replaced.
2. Remove the spark plug so the engine can be rotated more easily.
3. Rotate the engine to top dead center (TDC) of the compression stroke. Looking through the spark plug hole, the piston should be at the top.
4. Both the rocker arms should be loose at TDC on the compression stroke. If they are not, rotate the engine 360°.
5. Insert a feeler gauge between the rocker arm and the push rod and check for clearance (see Figure 20). See table below for valve lash specifications

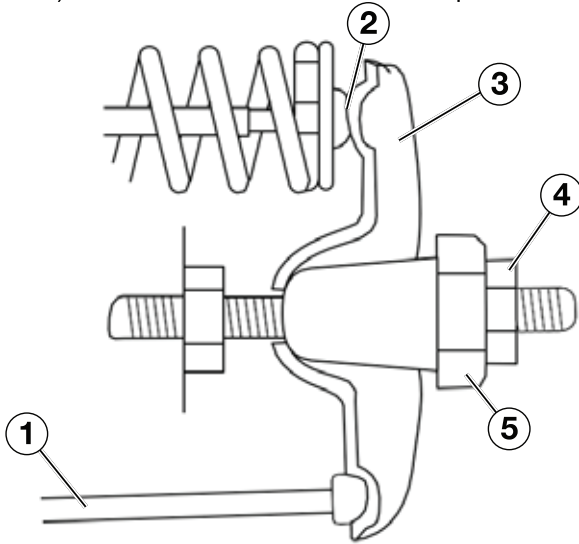

Figure 20

(1) Push Rod, (2) Feeler Gauge Area
(3) Rocker Arm, (4) Jam Nut, (5) Adjusting Nut

GT15000E Standard Valve Lash

| | Intake Valve | Exhaust Valve |
|--------------------|--|--|
| Valve Lash | 0.0031 ± 0.0047 in (0.08 ± 0.12 mm) | 0.0051 ± 0.0066 in (0.13 ± 0.17 mm) |
| Bolt Torque | 8-12N.m | 8-12N.m |

6. If an adjustment is required, hold the adjusting nut and loosen the jam nut.

7. Turn the adjusting nut to obtain the correct valve

lash. When the valve lash is correct, hold the adjusting nut and tighten the jam nut to 106 in-lb (12 N·m).

8. Recheck the valve lash after tightening the jam nut.
9. Perform this procedure for both the intake and exhaust valves.
10. Install the rocker arm cover, gasket and spark plug.

BATTERY SERVICE

To ensure the battery remains charged, the generator should be started every 2 to 3 months and run for a minimum of 15 minutes. If battery is flat, remove battery from machine and charge using an appropriate 12V charger.

Battery Replacement

1. Remove the spark plug wire from spark plug.
2. Loosen and remove the bolts on the battery hold down plate and swing the plate out.
3. Tip the battery forward slightly to access battery cables.
4. Disconnect the black negative (-) battery cable from the battery first.
5. Disconnect the red positive (+) battery cable second and remove the battery.

NOTICE

Dispose of the used battery properly according to the guidelines established by your local or state government.

6. Install the new battery into the generator frame.
7. Connect the red positive (+) battery cable to the battery first.

MAINTENANCE

8. Connect the black negative (-) battery cable to the battery second.
9. Install the battery hold-down plate using the nuts removed in step 2.
10. Install the spark plug wire onto spark plug.

See below for the battery specification when replacing the battery.

| Model | GT15000E |
|------------|---------------------------|
| Volts | 12V |
| Amp Hr | 21 |
| Dimensions | 7 1/8in by 3in x 6 9/16in |

CLEANING THE GENERATOR

It is important to inspect and clean the generator before every use.

Clean All Engine Air Inlet and Outlet Ports – Make sure all engine air inlet and outlet ports are clean of any dirt and debris to ensure the engine does not run hot.

Clean All Engine Cooling Fins – Use a damp rag and a brush to loosen and remove all dirt on or around the engine's cooling fins.

Clean All Alternator Cooling Air Inlets and Exhaust Ports – Make sure the cooling air inlets and exhaust ports of the alternator are free of any debris and obstructions. Use a vacuum cleaner to remove dirt and debris stuck in the cooling air inlets and exhaust ports.

General Cleaning of the Generator – Use a damp rag to clean all remaining surfaces.

CLEANING SPARK ARRESTOR

Check and clean the spark arrestor after every 100 hours of use or 6 months.

1. Generator must be cold to perform this maintenance.
2. Remove the 4 bolts that secure the end of the muffler cover.
3. Once the cover is removed, locate the screw on the tip of the muffler and remove. Pull the spark arrestor off the muffler.
4. If the spark arrestor screen shows signs of wear (rips, tears or large openings in the screen), replace the spark arrestor screen.
5. If screen is not torn then clean using a wire brush, commercial solvent, or compressed air. Remove any dirt and debris that may have collected on the spark arrestor screen.
6. Install the spark arrestor back into the muffler. Make sure to fully push it in so that it is tight on the tip of the muffler.
7. Replace the muffler cover and tighten all 4 screws.

STORING GENERATOR

WARNING



Never store a generator with fuel in the tank indoors or in a poorly ventilated area where the fumes can come in contact with an ignition source such as a: 1) pilot light of a stove, water heater, clothes dryer or any other gas appliance; or 2) spark from an electric appliance.

NOTICE

Gasoline stored for as little as 60 days can go bad, causing gum, varnish and corrosive buildup in fuel lines, fuel passages and the engine. This corrosive buildup restricts the flow of fuel, preventing an engine from starting after a prolonged storage period.

Proper care should be taken to prepare the generator for any storage.

1. Make sure the Engine Switch is switched to **OFF** so the generator does not draw power from battery.
2. Clean the generator.
3. Drain all gasoline from the fuel tank as best as possible.
4. With the fuel shut off valve open, start the engine and allow the generator to run until all the remaining gasoline in the fuel lines and carburetor is consumed and the engine shuts off.
5. Close the fuel shut off valve.
6. Change the oil (see *Changing Engine Oil*).
7. Remove the spark plug (see *Spark Plug Maintenance*) and place about 1 tablespoon of oil in the spark plug opening. While placing a clean rag over the spark plug opening, slowly pull the coil handle to allow the engine to turn over several times. This will distribute the oil and protect the cylinder wall from corroding during storage.
8. Replace the spark plug (see *Spark Plug Maintenance*).
9. Move the generator to a clean, dry place for storage.

TROUBLESHOOTING

⚠ WARNING



Before attempting to service or troubleshoot the generator, the owner or service technician must first read the owner's manual and understand and follow all safety instructions. Failure to follow all instructions may result in conditions that can lead to voiding of the EPA certification or product warranty, serious personal injury, property damage or even death.

| PROBLEM | POTENTIAL CAUSE | SOLUTION |
|---|--|--|
| Engine is running, but no electrical output | 1. Circuit breakers are tripped. | 1. Reset the circuit breakers and check for overload condition. |
| | 2. The power cord's plug connector is not fully engaged in the generator's outlet. | 2. Verify plug connector is firmly engaged in the generator's outlet. If using the 240V outlet, make sure plug connector is rotated 1/4 turn in the clockwise direction. |
| | 3. Faulty or defective power cord | 3. Replace power cord. |
| | 4. Faulty or defective electrical appliance | 4. Try connecting a known good appliance to verify the generator is producing electrical power. |
| | 5. GFCI outlet is tripped | 5. Switch the GFCI breaker to operating position. |
| | 6. If trying 1-5 above does not solve the problem, the cause might be the generator has a fault. | 6. Take the generator to your nearest authorized service dealer. |

| | | |
|--|---|---|
| Engine will not start or remain running while trying to start. | 1. Fuel shutoff valve is in the OFF position. | 1. Move the fuel shut off valve to the ON position. |
| | 2. Generator is out of gasoline. | 2. Add gasoline to the generator. |
| | 3. Fuel flow is obstructed. | 3. Inspect and clean fuel delivery passages. |
| | 4. Starting battery may have insufficient charge | 4. On electric start models only. Check battery output and charge battery as necessary. |
| | 5. Dirty air filter | 5. Check and clean the air filter. |
| | 6. Low oil level shut down switch is preventing the unit from starting. | 6. Check oil level and add oil if necessary. |
| | 7. Spark plug boot is not fully engaged with the spark plug tip. | 7. Firmly push down on the spark plug boot to ensure the boot is fully engaged |
| | 8. Spark plug is faulty. | 8. Remove and check the spark plug. Replace if faulty. |
| | 9. Stale fuel | 9. Drain fuel and replace with fresh fuel. |
| | 10. If trying 1-9 above does not solve the problem, the cause might be the generator has a fault. | 10. Take the generator to your nearest authorized service dealer. |

TROUBLESHOOTING

| PROBLEM | POTENTIAL CAUSE | SOLUTION |
|--|--|---|
| Remote start system not working. | 1. Low battery in remote start key fob | 1. Replace batteries in key fob. |
| | 2. Exceeding the range of remote start key fob | 2. Move closer to generator. Must be no more than 100 ft away. |
| | 3. Remote start key fob not programmed to generator | 3. Program key fob to generator. |
| Generator suddenly stops running. | 1. Generator is out of fuel. | 1. Check fuel level. Add fuel if necessary. |
| | 2. The low oil shut down switch has stopped the engine. | 2. Check oil level and add oil if necessary . |
| | 3. Too much load | 3. Restart the generator and reduce the load. |
| | 4. If trying 1-3 above does not solve the problem,the cause might be a fault in the generator. | 4. Take the generator to your nearest authorized service dealer. |
| Engine runs erratic; does not hold a steady RPM. | 1. Dirty air filter | 1. Clean the air filter. |
| | 2. Applied loads maybe cycling on and off | 2. As applied loads cycle, changes in engine speed may occur; this is a normal condition. |
| | 3. If trying 1-2 above does not solve the problem, the cause might be a fault in the generator | 3. Take the generator to your nearest authorized service dealer. |

GT15000E EXPLODED VIEW

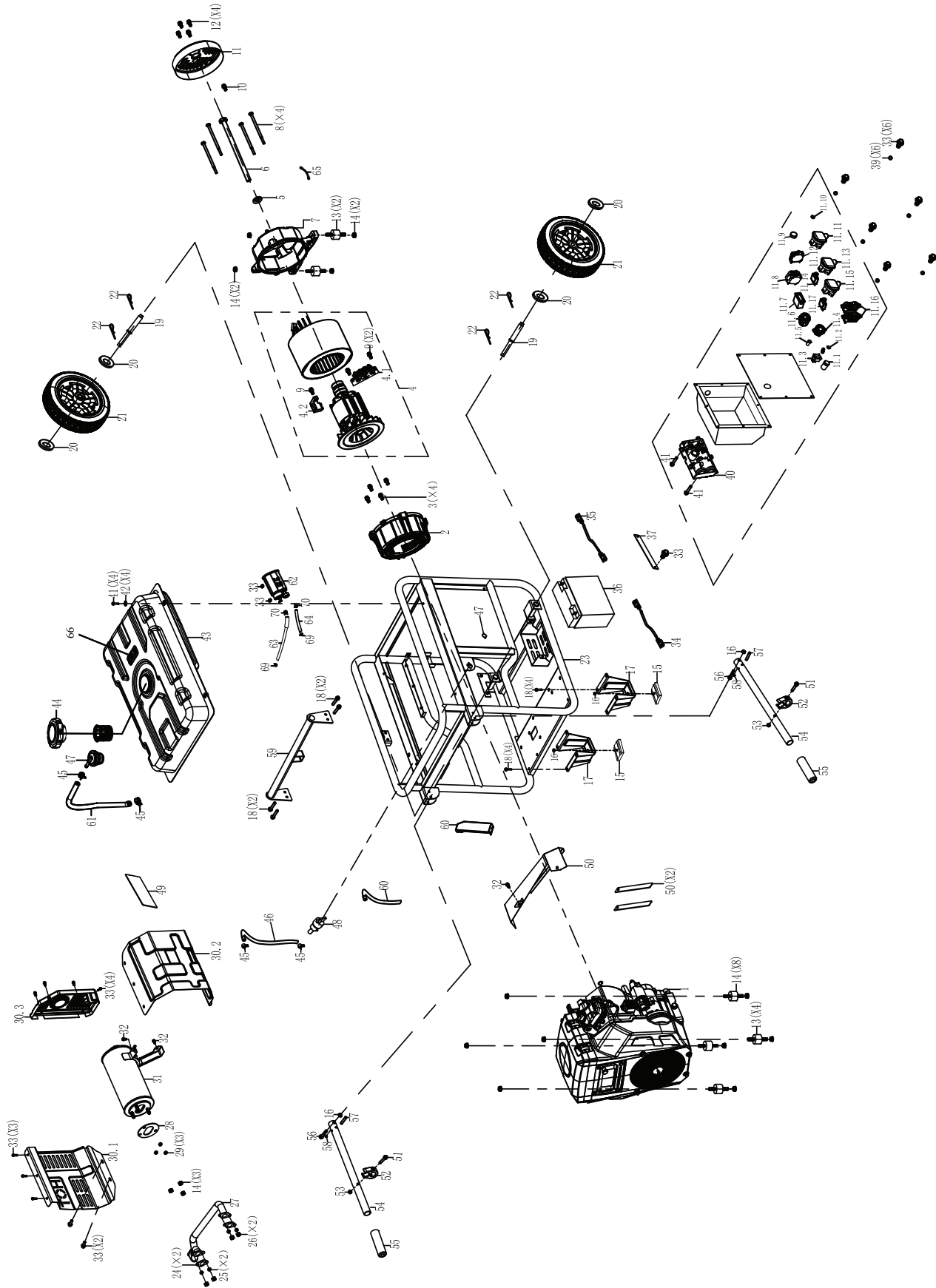

GT15000E EXPLODED VIEW

| NO. | DESCRIPTION |
|--------|---------------------------|
| 1 | ENGINE |
| 2 | FRONT COVER, ALTERNATOR |
| 3 | BOLT M10x1.25 |
| 4 | ALTERNATOR ASSEMBLY |
| 4.1 | GROUNDING POST COMP |
| 4.2 | CARBON BRUSH COMP |
| 5 | WASHER,CRANKSHAFT |
| 6 | BOLT M10*1.25*295 |
| 7 | BRACKET, ALTERNATOR |
| 8 | SCREW, STATOR M8*1.25*215 |
| 9 | BOLT M5*16 |
| 10 | BOLT M5*12 |
| 11 | END COVER, ALTERNATOR |
| 12 | BOLT M6X12 |
| 13 | ISOLATOR A |
| 14 | NUT M10*1.5 |
| 15 | VIBRATION ISOLATE |
| 16 | NUT, HEX |
| 17 | BRACKET, FRAME |
| 18 | BOLT M8*16 |
| 19 | AXLE |
| 20 | FLAT WASHER |
| 21 | WHEEL |
| 22 | COTTER PIN |
| 23 | FRAME |
| 24 | GASKET, EXHAUST |
| 25 | SPRING WASHER Ø8 |
| 26 | NUT M8 |
| 27 | EXHAUST PIPE |
| 28 | GASKET, EXHAUST PIPE |
| 29 | SPRING WASHER Ø10 |
| 30.1-3 | SHIELD, OUT MUFFLER |
| 31 | MUFFLER COMP |
| 32 | BOLT |
| 33 | BOLT |
| 34 | POSITIVE LEAD |
| 35 | NEGATIVE LEAD |
| 36 | BATTERY |
| 37 | PLATE,BATTERY |
| 38 | CONTROL PANEL ASSY. |
| 38.1 | PUSH BUTTON START SWITCH |
| 38.2 | INDICATOR LIGHT |
| 38.3 | START STOP SWITCH |
| 38.4 | SMART SWITCH |

| NO. | DESCRIPTION |
|-------|---|
| 38.5 | BATTERY CHARGING PORT 2.5MM |
| 38.6 | DOUBLE USB SOCKET |
| 38.7 | VFT METER |
| 38.8 | THE CIRCUIT BREAKER |
| 38.9 | SWITCH |
| 38.10 | GROUND BOLT ASSEMBLY |
| 38.11 | THE SOCKET 14-30R/UL |
| 38.12 | THE CIRCUIT BREAKER |
| 38.13 | SOCKET L14-30R/UL |
| 38.14 | THERMAL PROTECTOR 30A |
| 38.15 | AMERICAN THREE-HOLE PLUG SOCKET |
| 38.16 | AMERICAN DOUBLE SOCKET. 5-20R/UL |
| 38.17 | THERMAL PROTECTOR 30/1P/20A |
| 39 | THE PAPER GASKET |
| 40 | AUTOMATIC VOLTAGE REGULATOR |
| 41 | BOLT M6*25 |
| 42 | WASHER FUEL TANK |
| 43 | FUEL TANK |
| 44 | FUEL TANK CAP COMP |
| 45 | CLIP, FUEL LINE |
| 46 | FUEL LINE Ø12.5xØ6.2X430MM |
| 47 | PIN HANDLE |
| 48 | FUEL COCK |
| 49 | INSULATION, HIGH TEMPERATURE |
| 50 | SHROUD |
| 51 | BOLT M6*50 |
| 52 | CARD, RUBBER |
| 53 | NUT M6 |
| 54 | HANDLE ASSEMBLY |
| 55 | RUBBER, HANDLE |
| 56 | BOLT M8*50 |
| 57 | PIN HANDLE |
| 58 | HANDLE BUMPER PADS |
| 59 | HOOK |
| 60 | HEAT SHIELD |
| 61 | THE CONTROLLER |
| 62 | CARBON TANK COMPONENTS |
| 63 | LONG CARBON CONNECTING PIPE |
| 64 | THE CARBON TANK IS CONNECTED TO THE FUEL TANK |
| 65 | SHORT WIRES |
| 66 | FUEL GAGE |
| - | 1.6L OIL BOTTLE |
| - | REMOTE KEY FOB |

GT15000E ENGINE VIEW

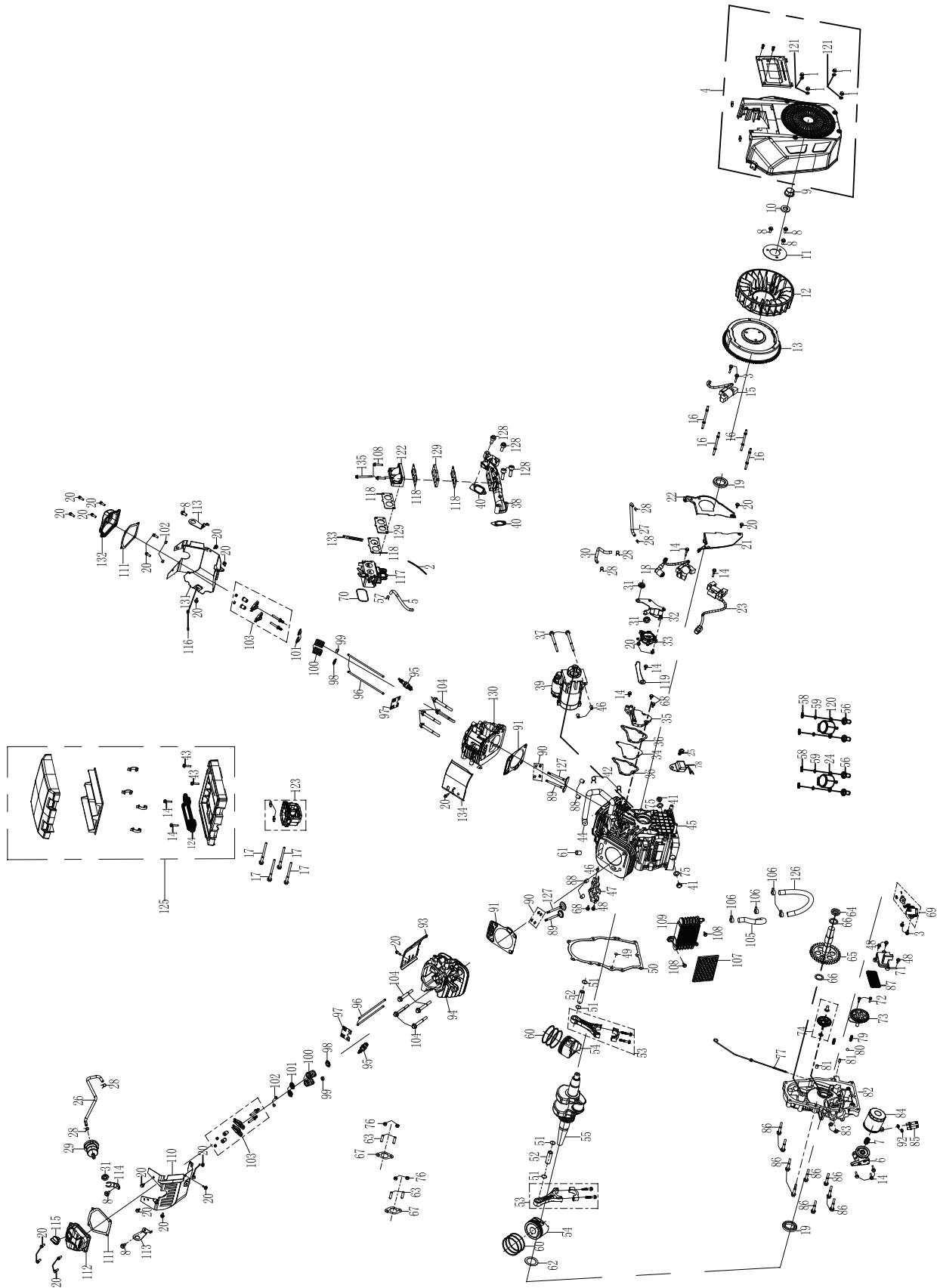

GT15000E ENGINE VIEW

| NO. | DESCRIPTION |
|-----|-----------------------------------|
| 1 | NUT M6 |
| 2 | HARNESS, FUEL CUT SOLENOID |
| 3 | BOLT M6X35 |
| 4 | RECOIL STARTER ASSEMBLY |
| 5 | FUEL TUBE |
| 6 | OIL FILTER BASE |
| 7 | CONNECTING PIPE, OIL FILTER |
| 8 | BOLT M8X16 |
| 9 | NUT M20 |
| 10 | FAN FLAT WASHER |
| 11 | PLATE, FAN FIXED |
| 12 | FAN |
| 13 | FLYWHEEL ASSEMBLY |
| 14 | BOLT M6X30 |
| 15 | CHARGE COIL |
| 16 | BOLT M6X113 |
| 17 | BOLT M6X95 |
| 18 | LEFT IGNITION COIL ASSY. |
| 19 | OIL SEAL |
| 20 | BOLT M6X12 |
| 21 | WIND SHIELD, LH |
| 22 | WIND SHIELD, RH |
| 23 | RIGHT IGNITION COIL ASSY. |
| 24 | STEPPER MOTOR DRIVE SHAFT RIGHT |
| 25 | BOLT M6X22 |
| 26 | FUEL TUBE, PUMP IN |
| 27 | FUEL TUBE, PUMP OUT |
| 28 | FUEL LINE CLIP |
| 29 | FILTER, FUEL |
| 30 | FUEL TUBE, PUMP NEGATIVE PRESSURE |
| 31 | RUBBER |
| 32 | BRACKET, FUEL PUMP |
| 33 | FUEL PUMP |
| 34 | DIAPHRAGM, BREATHER |
| 35 | COVER, BREATHER |
| 36 | BREATHER GASKET |
| 37 | BOLT M8X110 |
| 38 | INTAKE PIPE |
| 39 | STARTING MOTOR ASSEMBLY |
| 40 | INTAKE PIPE GASKET |
| 41 | BOLT DRAIN PLUG M14X1.5X12 |
| 42 | BREATHER TUBE CLIP |
| 43 | BOLT M6X25 |
| 44 | BREATHER TUBE |

| NO. | DESCRIPTION |
|-----|----------------------------------|
| 45 | CRANKCASE |
| 46 | PIN DOWEL Ø8X12 |
| 47 | SUPPORTING SEAT ASSY, ROCKER |
| 48 | BOLT M6X20 |
| 49 | WASHER |
| 50 | CRANKCASE GASKET |
| 51 | CLIP, PISTON |
| 52 | PIN, PISTON |
| 53 | ROD ASSEMBLY., CONNECTING |
| 54 | PISTON |
| 55 | CRANKSHAFT ASSEMBLY |
| 56 | SCREW M3X6 |
| 57 | FUEL LINE CLAMP |
| 58 | SPRING WASHERS 3.2MM |
| 59 | FLAT PAD 3.2MM |
| 60 | SCRAPER RING SET, PISTON |
| 61 | PLUG Ø 14 |
| 62 | CRANKSHAFT FLAT WASHER |
| 63 | BOLT M8X38 |
| 64 | BALL BEARING |
| 65 | CAMSHAFT ASSEMBLY |
| 66 | CAMSHAFT FLAT WASHER |
| 67 | GASKET, EXHAUST |
| 68 | BOLT M6X16 |
| 69 | SWITCH ASSEMBLY, OIL LEVEL |
| 70 | GASKET, AIR FILTER PIPE |
| 71 | STRAINER COVER |
| 72 | PHILLIPS SCREW M6X16 |
| 73 | OIL PUMP ASSY |
| 74 | GOVERNOR ASSEMBLY |
| 75 | FLAT WASHER |
| 76 | NUT M8 |
| 77 | DIPSTICK |
| 78 | AMPLIFIER |
| 79 | SPRING, PRESSURE RELEASE |
| 80 | STEEL BALL |
| 81 | PIN DOWEL |
| 82 | COVER CRANKCASE |
| 83 | WASHER Ø11.2*Ø2.65 |
| 84 | OIL FILTER |
| 85 | CONNECTING PIPE, OIL FILTER BASE |

GT15000E ENGINE VIEW

| NO. | DESCRIPTION |
|-----|---|
| 86 | BOLT M8X50 |
| 87 | STRAINER, OIL |
| 88 | CRANKCASE DOWEL PIN |
| 89 | VALVE, IN |
| 90 | LOCKING FLAPS |
| 91 | CYLINDER HEAD GASKET |
| 92 | FLAT WASHER $\phi 10.2 \times \phi 17 \times 1$ |
| 93 | LEFT SHROUD |
| 94 | CYLINDER HEAD, L |
| 95 | SPARK PLUG |
| 96 | ROD, PUSH |
| 97 | PLATE, PUSH ROD GUIDE |
| 98 | RETURNER, INTAKE VALVE |
| 99 | OIL SEAL, VALVE |
| 100 | SPRING, VALVE |
| 101 | SEAT, VALVE SPRING |
| 102 | ROTATOR |
| 103 | ROCKER ASSY |
| 104 | BOLT M10X80 |
| 105 | SHORT OIL TUBE |
| 106 | CLIP, FUEL TUBE |
| 107 | BRACKET, HEAT RADIATOR |
| 108 | BOLT M6X28 |
| 109 | HEAT RADIATOR |
| 110 | SHROUD, L |
| 111 | HEADCOVER GASKET |
| 112 | COVER COMP, CYLINDER HEAD, L |
| 113 | LUG |
| 114 | BRACKET, TUBE |
| 115 | OIL PLUG |
| 116 | TEMPERATURE SENSOR |
| 117 | CARBURETOR ASSEMBLY |
| 118 | GASKET, CARBURETOR |
| 119 | CLAMPER CORD A |
| 120 | STEPPER MOTOR DRIVE SHAFT LEFT |
| 121 | RUBBER WASHER |
| 122 | PIPE, CARBURETOR |
| 123 | CONNECTING PIPE |
| 124 | PLATE |
| 125 | AIR CLEANER ASSEMBLY |

| NO. | DESCRIPTION |
|-----|---|
| 126 | LONG OIL TUBE |
| 127 | VALVE EXHAUST |
| 128 | PHILLIPS SCREW M8X50 |
| 129 | SPACER, CARBURETOR |
| 130 | CYLINDER HEAD, R |
| 131 | SHROUD, R |
| 132 | COVER COMP, CYLINDER HEAD, R |
| 133 | CLIP, WIRE HARNESS |
| 134 | RIGHT SHROUD |
| 135 | BOLT M6X65 |
| - | HIGH ALTITUDE CARBURETOR ASSY (SOLD SEPARATE) |

GT15000E SCHEMATIC

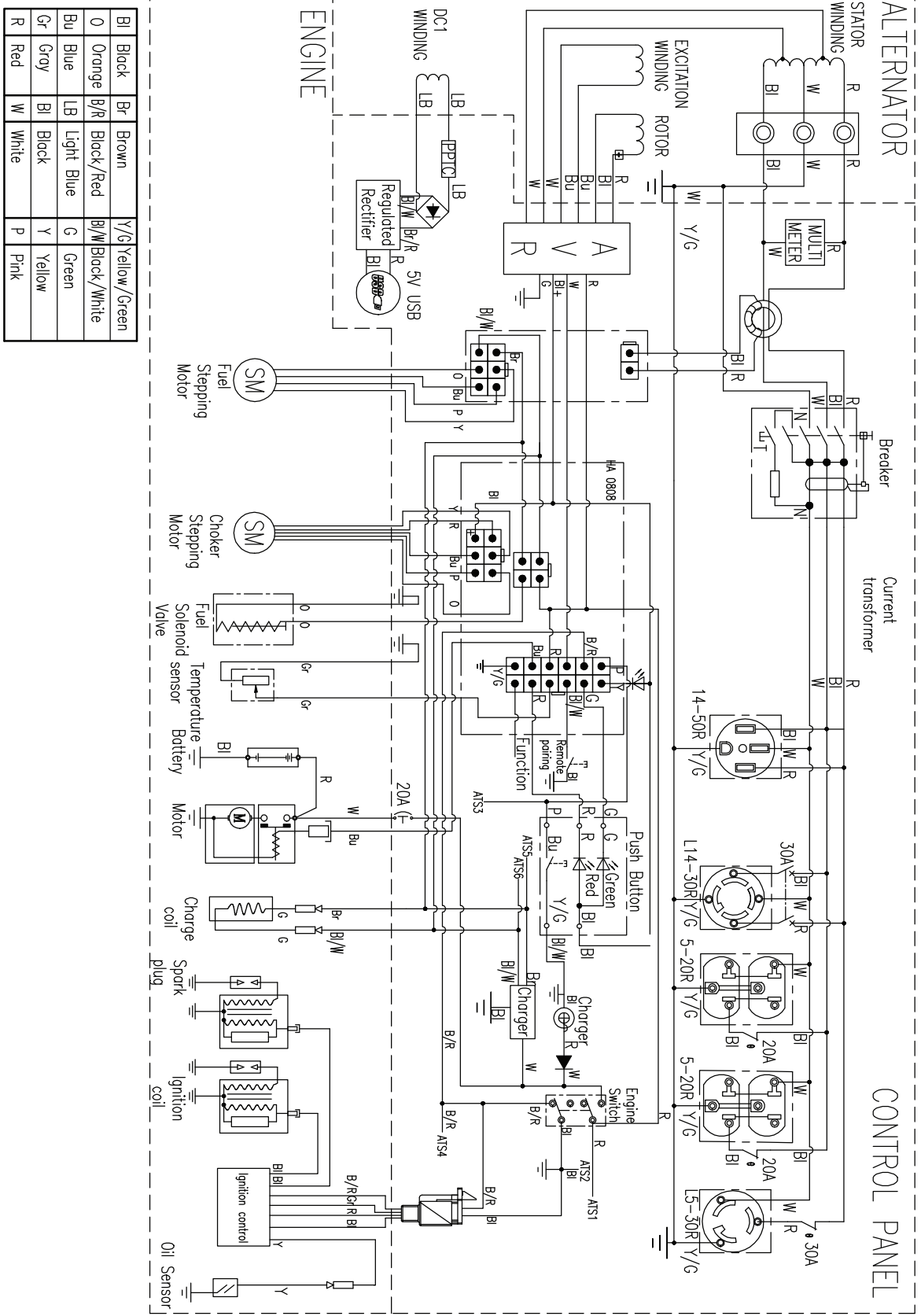

WARRANTY

As part of an on-going commitment to excellence in product support, Euroquip offers a comprehensive product warranty program.

1. THIS WARRANTY:

The benefits provided to the consumer in this warranty are in addition to other rights and remedies of a consumer under the New Zealand Consumer Guarantees Act 1993 and any other laws in relation to the products to which this warranty relates. This warranty:

- Covers the product against faulty materials or workmanship; and
- Covers the replacement of parts, the repair labour used, a refund of the price of the product or replacement of the machine, or other compensation for the remainder of the warranty period.

This product warranty is only applicable to the original purchaser of the machine and only purchases made from Euroquip Authorized Retailers.

2) WARRANTY PERIODS:

Commercial Warranty*: 2 Years (24 months)
Domestic Warranty* : 4 Years (48 months)

Domestic Warranty applies to domestic use of the product: Personal, residential, or household use only. Commercial Warranty applies to commercial or business use of the product: All uses other than domestic use, including use for income-producing (including farming) or rental purposes.

*These GT Power Warranty periods are for products that are:

- Purchased from a New Zealand GT Power Dealer after 01/06/23
- Serviced by a GT Power Dealer in accordance with the GT Power service schedule, using genuine parts and the correct grade of oil (proof required)
- Meeting all other warranty requirements

NOTE: These warranty conditions apply to New Zealand only.

Euroquip warrants each new GT Power machine free from defect in material and workmanship under normal use and routine servicing, for the warranty periods specified. Conditional to the limitations and exclusions list below. The warranty period begins when the product is purchased by the end user. Warranty is not transferrable and is only claimable by the original purchaser.

Proof of purchase documentation with product serial number must be provided. If it has been lost and Euroquip does not have a record of the purchaser's details, the warranty period shall be calculated from the appropriate dealer wholesale sale date.

The purchaser must keep a record of all service and maintenance history as proof of servicing history. This may be requested when assessing any future warranty claims. The decision that an issue with a product qualifies as a warranty claim is made at the sole jurisdiction of Euroquip.

No costs incurred will be considered under warranty if repairs or maintenance are carried out by any party other than a Euroquip Approved Service Agent, unless with prior consent in writing from Euroquip.

It is the full responsibility of the purchaser to deliver the product under warranty to the nearest relevant service agent or product reseller. Warranty does not cover transportation costs including call outs, mileage and freight costs.

Customers are responsible for the care and cleaning of their product prior to sending it to our service centre. Any product being sent us must be thoroughly cleaned. Depending on what the product has come into contact with, it could pose an Occupational/ Work Health and Safety risk for our staff and or/service agents to inspect, repair or service a product that has come into contact with a hazardous substance. If we are asked to inspect, repair or service a product that has come into contact with a hazardous substance such as chemicals, asbestos or silica dust, we may not be able to inspect, service or repair the product. If this is the case, we will inform the purchaser and the product will be returned.

If a product is repaired under warranty, parts and labour required for the repair will be supplied at no charge. All defective parts replaced under warranty become property of Euroquip. Consumable items such as, but not limited to, oils, coolants, filter and spark plugs shall be the responsibility of the owner. Warranty assessment and repair will be scheduled and executed according to the normal work flow at the service location and depending on the availability of suitable replacement parts.

This warranty policy is an additional benefit and does not supersede the legal rights of any customer, reseller or service agent.

Should any issue be found to be a combination of a warranty failure and a non-warranty issue such as incorrect charging techniques, the repair cost component to rectify and repair the non-warranty failure is the **customer's** full responsibility.

WARRANTY

3) EXCLUSIONS:

- Warranty does not cover parts that are subject to wear and tear from usage and/or damage which results from neglect of periodic maintenance.
- Evidence must be provided that the product has been maintained and serviced suitably for a claim to be considered under warranty.
- Batteries supplied with your product are warranted against defect for 3 months and does not include lack of charge due to non-use. Consumable items such as, but not limited to, oils, coolants, filters, spark plugs and batteries shall be the responsibility of the purchaser.
- Failure caused by incorrect operation of the product as specified in the manual either intentionally or by error.
- Lack of proper care and maintenance of the product.
- Any damage which results from unavoidable natural disasters, fire, collision, theft, etc.
- Any normal wear or deterioration, such as that of sliding or rotating parts caused under normal operating conditions.
- Any damage that results from misuse or use beyond the imitations of the products intended purpose (such as overloading or use under abnormal conditions).
- External circumstances such as product deterioration or corrosion due to environmental conditions like heat, cold, salt spray, sand or due to the passage of time
- Normal phenomena such as noise, vibration or oil seepage which are considered by Euroquip as not affecting the quality, function or performance of the product.
- Any damage due to improper storage or transport.
- Consumable replacement items: Spark plugs, contact points, shear pins, fuel strainers, oil filter elements, air cleaner elements, brake shoes or pads, clutch components, fuses, motor brushes, gaskets, tube or hoses, belts, cutting blades, light bulbs, serviceable bearings. Petroleum and others fluids: Oil, grease, battery electrolyte, and radiator coolant. Other items specified by Euroquip.
- Periodical maintenance items such as cleaning, inspection and adjustments.
- Contaminated fuel
- Modifications or installations of other products to the product
- Damage that results from the use of non-genuine parts, lubricant or fluid not approved by Euroquip
- Any repair and/or adjustment to correct improper or poor quality work previously performed.
- Attempted repair/ service by a party other than an Approved Service Agent, or any repair undertaken prior to approval of warranty be Euroquip is not covered under warranty.
- Warranty does not cover pre delivery service and adjustment, or failure that may occur as a result of lack of/ incorrect pre delivery service and adjustment. Warranty does not cover any incidental, indirect or consequential loss, damage, personal injury, or expense that may result from any defect, failure, malfunction, or misuse of a product.
- Any product that is found to have come into contact with hazardous substances such as chemicals, asbestos or silica dust and NOT been industrially cleaned prior to servicing.

4) HOW TO CLAIM WARRANTY:

In the event you are faced with a manufacturing fault with your GT Power product, you can claim a repair or part replacement under warranty if the following conditions are fulfilled:

- The problem is related to production quality or specifications of the machine
- The machine is within the warranty period outlined in schedule
- The issue does not fall within the warranty exclusions listed

If the criteria above is met, and you would like to request a warranty, then please go online to <https://www.euroquip.co.nz/Service-Request-End-User> and log your warranty claim.



Congratulations on your new GT POWER product. We are proud to have you as our customer and will strive to provide you with the best service and reliability in the industry. This product is backed by our extensive warranty and service network. To locate your nearest distributor or service agency visit **www.euroquip.co.nz** or email us at **customerservice@euroquip.co.nz**.